

CENTER  POINT<sup>®</sup>  
ARCHERY

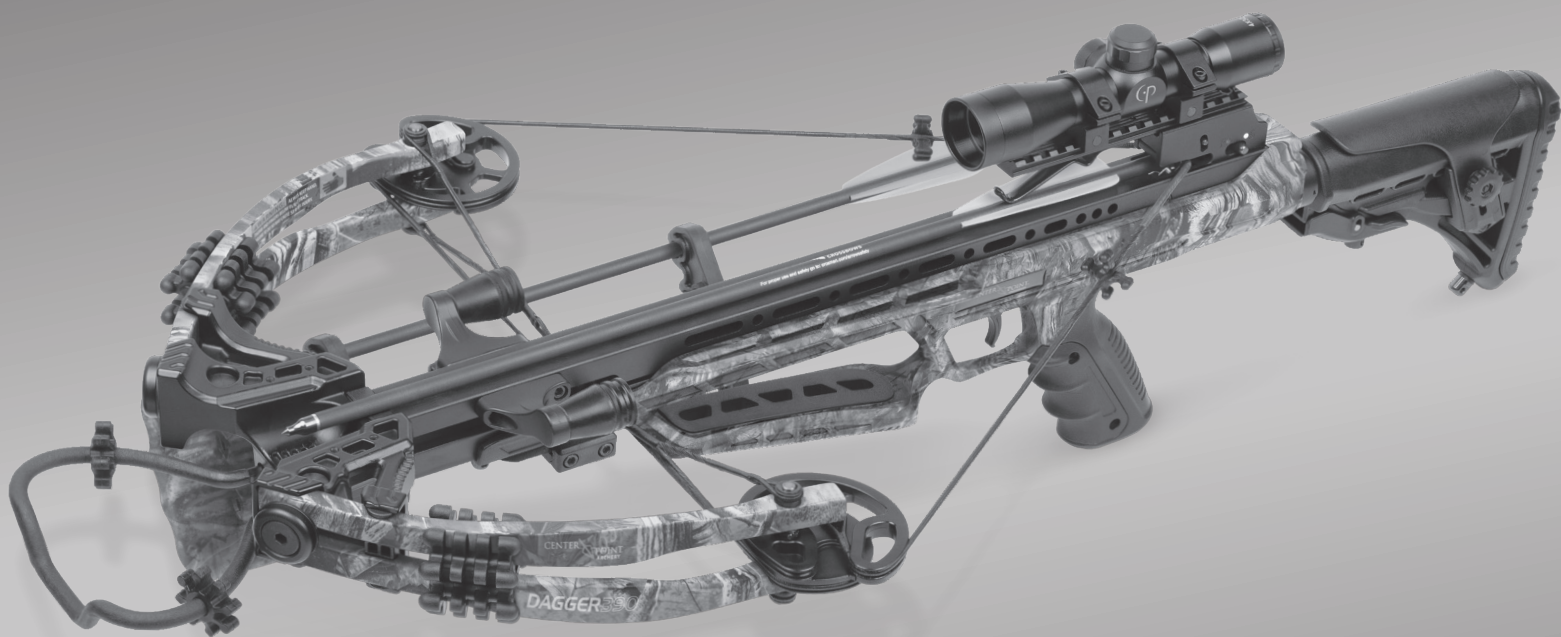

# **DAGGER<sup>™</sup>390**

COMPOUND CROSSBOW

OWNER'S MANUAL

## READ ALL INSTRUCTIONS AND WARNINGS BEFORE USING

If you have any questions about this product or need some help, do not return the product to the store before talking with CenterPoint Archery. Feel free to visit us at [centerpointarchery.com](http://centerpointarchery.com), or speak with one of our friendly customer service representatives (1-866-726-1122) Monday through Friday between the hours of 9AM and 4:30PM EST.

**⚠ WARNING:** RECOMMENDED FOR ADULT USE ONLY. MISUSE OR CARELESS USE MAY RESULT IN SERIOUS INJURY OR DEATH. READ ALL INSTRUCTIONS BEFORE USING. RETAIN INSTRUCTIONS AND SAFETY MANUAL FOR FUTURE REFERENCE.

**⚠ WARNING:** ALWAYS KEEP HAND, THUMB AND FINGERS BELOW THE RAIL. FAILURE TO DO SO MAY CAUSE SERIOUS INJURY.

**⚠ WARNING:** BUYER AND USER HAVE THE DUTY TO OBEY ALL LAWS ABOUT THE USE AND OWNERSHIP OF THIS CROSSBOW.

**⚠ WARNING:** THIS PRODUCT CAN EXPOSE YOU TO CHEMICALS INCLUDING LEAD, WHICH IS KNOWN TO THE STATE OF CALIFORNIA TO CAUSE CANCER, AND LEAD, WHICH IS KNOWN TO THE STATE OF CALIFORNIA TO CAUSE BIRTH DEFECTS OR OTHER REPRODUCTIVE HARM. FOR MORE INFORMATION GO TO [WWW.P65WARNINGS.CA.GOV](http://WWW.P65WARNINGS.CA.GOV).

### 1. SAFETY FIRST

#### A. Target Safety

- ALWAYS treat the crossbow as though it is loaded and ready to fire.
- ALWAYS treat the crossbow with the same respect you would a firearm.
- ALWAYS store the crossbow unloaded and away from children.
- ALWAYS check to see if the crossbow is "ON SAFE" and unloaded when transferring it from another person or from storage.
- ALWAYS keep the crossbow pointed in a SAFE DIRECTION.
- ALWAYS keep the crossbow "ON SAFE" until you are ready to shoot.
- ALWAYS keep finger off the trigger and out of the trigger guard until ready to shoot.
- ALWAYS be sure of your target and what is beyond.
- ALWAYS use crossbow approved target.
- ALWAYS check your archery backstop for wear before and after such use. All target backstops are subject to wear and will eventually fail. Replace your target backstop if the surface is worn or damaged.
- NEVER cock or load the crossbow until you are ready to shoot.
- NEVER point the crossbow at any person.
- NEVER point the crossbow at anything you do not intend to shoot.
- NEVER rely on a mechanical device to replace safe handling practices.

#### B. Crossbow Safety

- ALWAYS check the crossbow thoroughly for worn, damaged, loose or missing parts prior to shooting.
- ALWAYS check your rope cocking device thoroughly for worn, damaged, loose or missing parts prior to shooting.
- ALWAYS inspect your arrows/bolts regularly. Damaged arrows/bolts may cause serious injury. Any nicked, dented, split, or splintered bolts should be discarded immediately.
- ALWAYS keep hands, fingers and thumbs below the travel path of the bow string and below the rail.
- ALWAYS be sure the crossbow limbs are clear from striking tree limbs and other obstacles before shooting.
- ALWAYS wear safety glasses with any type of archery product.
- NEVER dry fire the crossbow. Shooting without an arrow/bolts will cause damage to your crossbow and could cause injury to the shooter.
- NEVER use underweight arrows/bolts. This has the same effect as dry-firing a crossbow and may cause damage to the crossbow and injury to the shooter.
- NEVER shoot any projectile in the crossbow except for arrows/bolts recommended by CenterPoint Archery for the specific crossbow. Shooting other than recommended bolts could result in injury or damage to the crossbow (see specification chart for bolt information).
- NEVER draw your crossbow beyond the maximum draw length or damage to the limbs, cables and strings could occur.
- NEVER use your hand or the rope cocker to uncock the crossbow as it may cause serious injury to the user or damage to the crossbow.
- NEVER attempt to disassemble or tamper with the crossbow. Special tools are required for working on the crossbow. Contact an established archery shop for assistance. Using anything other than an established archery shop or modifying the function of the crossbow in any way may render the crossbow unsafe and will void the warranty.

## 2. PARTS LIST ( See Fig. 1)

Fig. 1

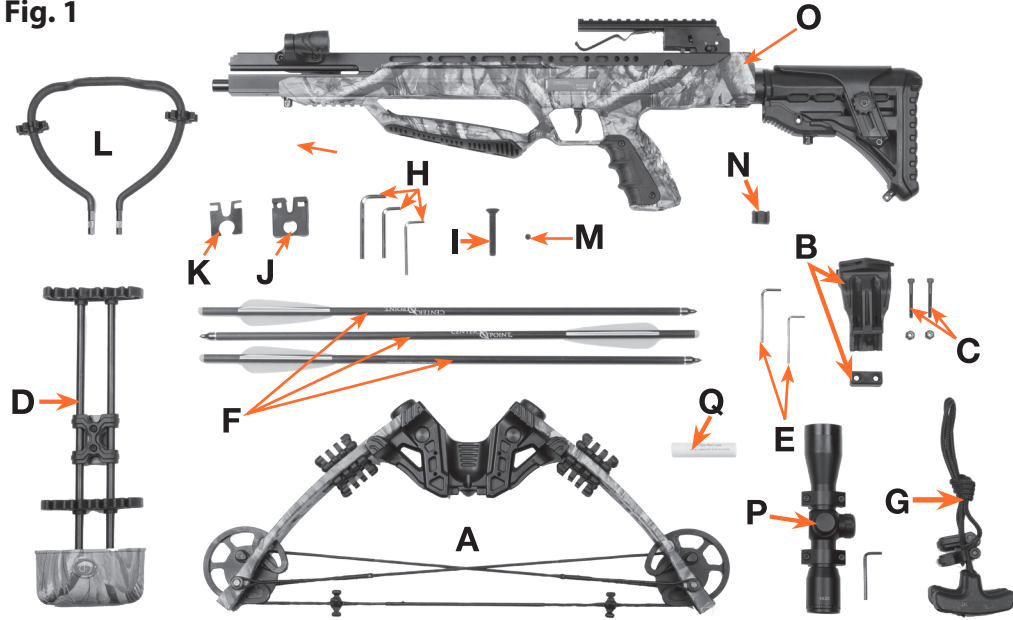

- A. Limbs/Riser Assembly (w/Strings/Cables)
- B. Quiver Mount (2pcs)
- C. Quiver Mount Screws (2)
- D. Quiver
- E. Quiver Hex Wrenches (2)

- F. 3 Arrows/Bolts
- G. Rope Cocker
- H. Assembly Hex Wrenches
- I. Riser Bolt
- J. Joint Cap
- K. Joint Cap Pad

- L. Foot Stirrup
- M. Riser Bolt Locking Screw
- N. Cable Slide
- O. Crossbow Main Body (Stock/Barrel)
- P. 4x32 Scope & Rings
- Q. Rail Lube

## 3. LEARNING THE PARTS OF THE CROSSBOW (See Fig. 2)

### Parts of a Compound Crossbow

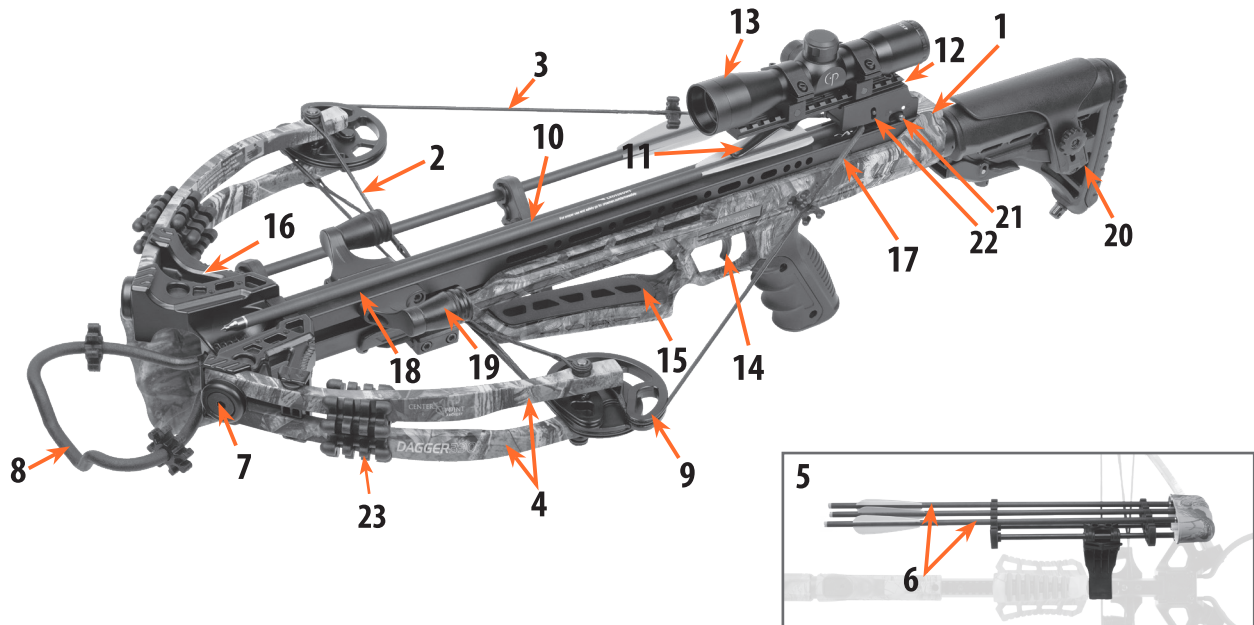

Fig. 2

- 1. Stock
- 2. Cables
- 3. String
- 4. Split Limb
- 5. Quiver
- 6. Bolts/Arrows
- 7. Limb Pocket
- 8. Foot Stirrup

- 9. Cam
- 10. Rail
- 11. Bolt/Arrow Retention Ball
- 12. Sight Bridge
- 13. Scope
- 14. Trigger
- 15. Fore Grip
- 16. Riser

- 17. (Center) Serving
- 18. Flight Groove
- 19. String Dampener
- 20. Adjustable Butt Stock
- 21. Safety Switch
- 22. Cocking Preparation Switch
- 23. Limb Dampeners

## 4. ASSEMBLING THE CROSSBOW

### A. Installing the Riser

1. Attach the cable slide to the cables. The cable slide has a larger gap on one side to properly slide onto the rail. (Fig. 3)
2. Slide the cable slide into the opening at the end of the rail while sliding the string down the top of the rail. (Fig. 4)
3. Attach the Joint Cap Pad to the Joint Cap. Slide the Joint Cap onto the rail. (Fig. 4)
4. Slide the riser onto the rail. Install and tighten the riser bolt using the hex wrench. Insert the Riser Bolt Set Screw to prevent the Riser Bolt from loosening. Tighten using hex wrench. (Fig. 5 & 6)

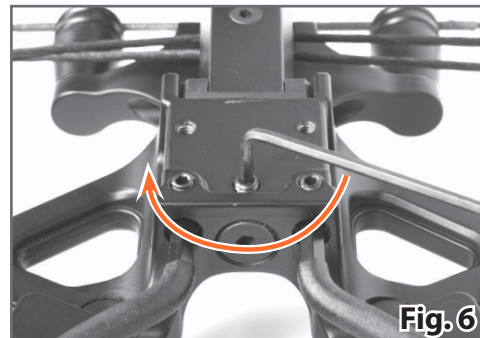
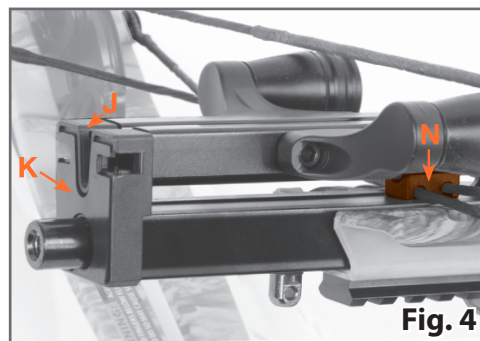
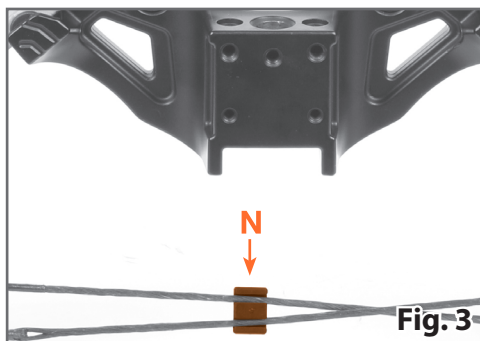

### B. Inserting the Stirrup

1. Insert the stirrup onto the riser by aligning the retention grooves to the set screw holes using the 2 screws using the hex wrench (Fig. 7 & 8)



**IMPORTANT:** Be sure that the bow unit is secured tightly before engaging crossbow. Assembly bolts may need to be retightened periodically after use.

### C. Assembling the Quiver

The Dagger 390 comes with a parallel quiver mount. It can be mounted onto the left or right side of your crossbow.

1. Loosen the screws on the mounting bracket and attach to the picatinny rail under the barrel, in front of the forearm.
2. Attach the quick disconnect quiver mount to the end of the mounting bracket (Fig 9).
3. Connect the quiver to the quiver mount by sliding the two mounts together and locking in place with the locking lever.
4. Ensure quiver is locked and secure.

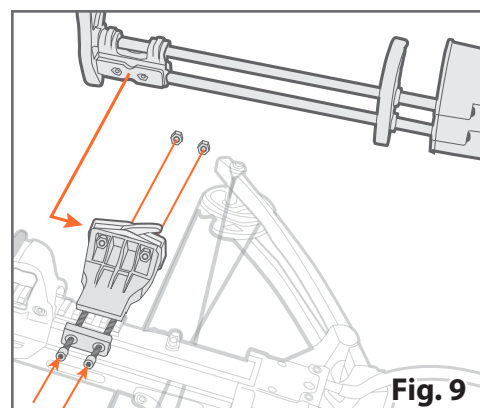

### D. Attaching the Scope

1. Attach the Scope mount rings onto the scope using the scope mount screws (4) (Fig. 10 A).
2. Position your scope by moving it forward or backward until the proper eye relief is found. This is typically three or four inches from your eye to the eyepiece when you are holding the crossbow in a shooting position. (Fig. 10 B)

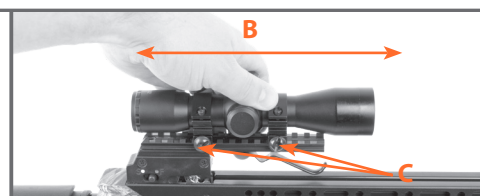

3. Align the scope mount with the slots on the sight bridge rail.
4. Align the screws with the grooves on the rail, and tighten screw heads with a screw driver (not included). (Fig. 10 C).

## E. Adjusting the Butt Stock Length

1. Press the lever on the bottom of the stock. (Fig. 11)
2. Slide the Stock from 0-5 to lengthen or shorten stock position.
3. Release the lever to lock into place.



## 5. OPERATING THE SAFETY

**CAUTION:** NEVER rely on a mechanical device to replace safe handling practices. Always handle the crossbow as if the crossbow was not ON SAFE. Like all mechanical devices, a crossbow safety can fail. Even when the safety is "ON SAFE," you should continue to handle the crossbow in a safe manner.

### A. To Put the Crossbow on "SAFE"

**NOTE:** The safety automatically is engaged and the safety switch moves to the ON SAFE position when the crossbow is cocked in a normal manner (see Section 6. COCKING THE CROSSBOW).

1. Make sure the crossbow is pointed in a SAFE DIRECTION.
2. Slide the safety switch from the FIRE position to the ON SAFE position. (Fig. 12)
3. The crossbow is ON SAFE when the safety switch is moved all the way back under the WHITE dot.
4. Carefully inspect the safety switch to ensure that it is fully in the ON SAFE position (Fig. 12). If the safety switch has not moved all the way back to the WHITE dot, it has not been placed ON SAFE and is still in FIRE position. Always visually inspect the safety switch to make certain that it is in the desired position.

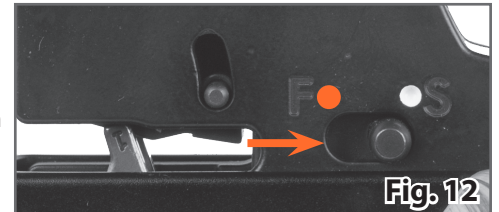

**⚠ WARNING:** IF FOR ANY REASON THE SAFETY SWITCH DOES NOT FULLY MOVE TO THE ON SAFE POSITION (FIG. 12), SAFELY DE-COCK THE BOW THROUGH THE USE OF AN ARROW AS DESCRIBED IN SECTION 8.D. DO NOT USE THE CROSSBOW. CALL CUSTOMER SERVICE AT 1-866-726-1122 FOR AUTHORIZED REPAIR.

### B. To Put the Crossbow on "FIRE"

**NOTE:** If attempting to cock the Crossbow and the safety switch is "ON SAFE", you will need to use the Cocking Preparation Switch to move the safety switch from the "ON SAFE" position to the "FIRE" position in order for the crossbow to accept the string when cocked. Follow the instructions on cocking and loading the crossbow (see Sections 6 & 7).

#### CAUTION:

- ONLY USE THE COCKING PREPARATION SWITCH (Fig. 2 #22) DURING THE NORMAL COCKING PROCEDURE TO MOVE THE SAFETY SWITCH FROM THE "ON SAFE" POSITION TO THE "FIRE" POSITION (SEE SECTION 6-COCKING THE CROSSBOW).
- DO NOT USE THE COCKING PREPARATION SWITCH AFTER THE CROSSBOW IS COCKED. USE OF THE COCKING PREPARATION SWITCH, WHILE THE CROSSBOW IS IN THE COCKED POSITION, WILL TURN OFF THE ANTI-DRY FIRE MECHANISM.
  1. Make sure the crossbow is pointed in a SAFE DIRECTION.
  2. Locate the safety switch on the side of the stock.
  3. Slide the safety switch from the ON SAFE position to the FIRE position. (Fig. 13)
  4. The crossbow is OFF SAFE and ready to FIRE when the safety switch is moved all the way forward under the RED dot ("FIRE").

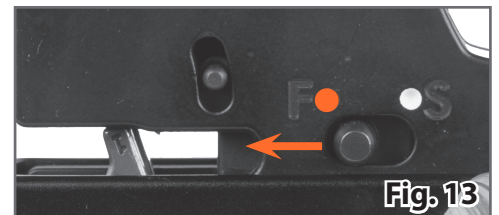

**IMPORTANT:** After the crossbow is cocked, the user should **ONLY** move the safety switch from the "ON SAFE" position to the "FIRE" position if an arrow/bolt is loaded.

## 6. COCKING THE CROSSBOW

**⚠ WARNING:** YOUR CROSSBOW FUNCTIONS BEST WHEN USING THE ROPE COCKING DEVICE DESIGNED FOR YOUR CROSSBOW. USE OF OTHER ROPE COCKERS WITH DIFFERENT ROPE LENGTHS AND HOOK DESIGN MAY BE UNSAFE TO THE USER AND MAY DAMAGE YOUR CROSSBOW.

#### CAUTION:

- DO NOT cock or load the crossbow unless in a safe area and in a position to load and shoot safely.
- Be sure to apply the rail lube to the rail. Apply string and cable wax to the NON-Served areas of the string and cables before cocking. **REMEMBER:** To cock the crossbow, the safety must be in the "FIRE" position. As you cock the crossbow the safety will engage to the "ON SAFE" position.

### A. If the Safety is ON SAFE:

1. Push and Hold the Cocking Preparation Switch forward. (Fig. 14)
2. While holding the Cocking Preparation Switch forward, slide the safety switch from the ON SAFE position to the FIRE position. (Fig. 14)
3. Release the Cocking Preparation Switch once the safety switch is in the FIRE position. (Fig. 14)

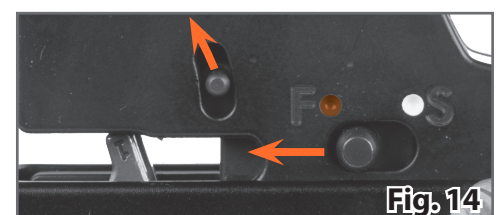

4. Place the cocking stirrup on the ground and place a foot securely inside. (Fig. 15)
5. Place the center of the cocking rope in the rope groove. (Fig. 16)
6. Place the hooks of the cocking rope onto the crossbow string on each side of the flight rail. (Fig. 15)
7. Pull both t-handles simultaneously, smoothly drawing the crossbow string back under the bolt retention spring and into the string opening of the trigger mechanism. (Tension will keep the cocking hooks against the rail if done properly. (Fig. 17)
8. Continue drawing until the trigger safety switch moves to the "ON SAFE" position. (Fig. 13)
9. Relax the tension slightly to ensure the trigger latch has fully captured the crossbow string. **NOTE:** The main string should click into place and the safety should automatically engage. If the string is being captured by the trigger latch, let go of the string.
10. Once cocked, remove the rope cocker hooks from the crossbow string.
11. The crossbow is now cocked and ready for loading an arrow/bolt.

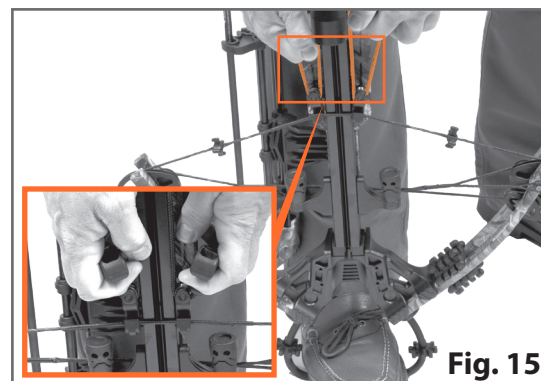

Fig. 15



Fig. 16



Fig. 17

**⚠ WARNING:** DO NOT USE YOUR HAND OR THE ROPE COCKER TO UNCOCK THE CROSSBOW AS IT MAY CAUSE SERIOUS INJURY TO THE USER OR DAMAGE TO THE CROSSBOW.

## 7. LOADING THE CROSSBOW

1. Verify the crossbow safety is ON SAFE.
2. Point the crossbow in a SAFE DIRECTION.
3. Be sure to use only arrows/bolts that are the recommended weight and size. (SPECIFICATION CHART for arrow/bolt information)
4. Grip the arrow near its point on the opposite end to the fletching. The crossbow may be loaded by keeping all hands and body parts out of the path of the bowstring and in the safe loading area (Fig. 18). Keep your hands, fingers and all other body parts out of the travel path of the string and cables at all times. The crossbow is designed so that the user never needs to place a body part into the path of the crossbow string. Failure to follow this warning could lead to serious injury or death.
5. Place the arrow/bolt so that the cocking vane (the odd colored vane), is down in the flight groove (Fig. 18)
6. Slide the arrow/bolt back to the trigger assembly, under the arrow/ bolt retention spring, until the arrow/ bolt half moon nocks rests fully on the string. (Fig. 18)
7. After following these steps and reading the entire manual, including the section on reviewing safety procedures, your crossbow is now loaded and ready to fire.

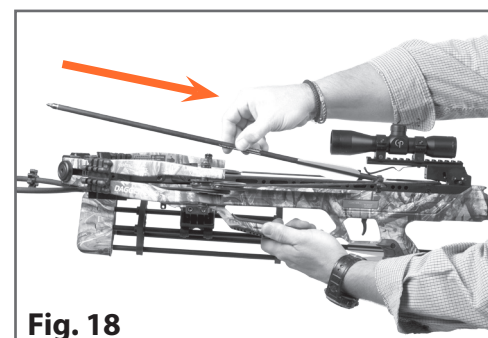

Fig. 18

**⚠ WARNING:** KEEP THE CROSSBOW IN THE "SAFE" POSITION UNTIL YOU ARE ACTUALLY READY TO SHOOT. THEN PUSH THE SAFETY FORWARD TO THE "FIRE" POSITION.

## 8. AIMING AND FIRING SAFELY

**⚠ WARNING:** KEEP FINGERS AND THUMB BELOW THE TRAVEL PATH OF THE CROSSBOW STRING AND CABLES. FAILURE TO DO SO COULD RESULT IN SERIOUS INJURY.

### A. Aiming the Crossbow

- Always point the crossbow in a SAFE DIRECTION.
- Always keep fingers and thumb below the travel path of the bow string. (Fig. 19)
- Eye Protection should be worn by all participants while shooting. With the crossbow pointed down range, shoulder the crossbow, and place your hand on the stock with your fingers and thumb positioned on the fore grip, below the travel path of the string (Fig. 19)
- Do not shoot at hard surfaces or at the surface of water. The arrow/bolt may bounce off or ricochet and hit someone or something you had not intended to hit.
- Always choose the target carefully.
- **THINK** about what you will hit if you miss the target.

**⚠ WARNING:** NEVER PLACE ANY PART OF YOUR BODY (INCLUDING HANDS OR FINGERS) INTO THE TRAVEL PATH OF THE CROSSBOW STRING OR CABLES. KEEP YOUR FRONT HAND ON THE FOREARM OF THE STOCK BELOW THE TRAVEL PATH OF THE STRING AND CABLES AT ALL TIMES (SEE FIG. 19). FAILURE TO FOLLOW THIS WARNING COULD LEAD TO SERIOUS INJURY OR DEATH.

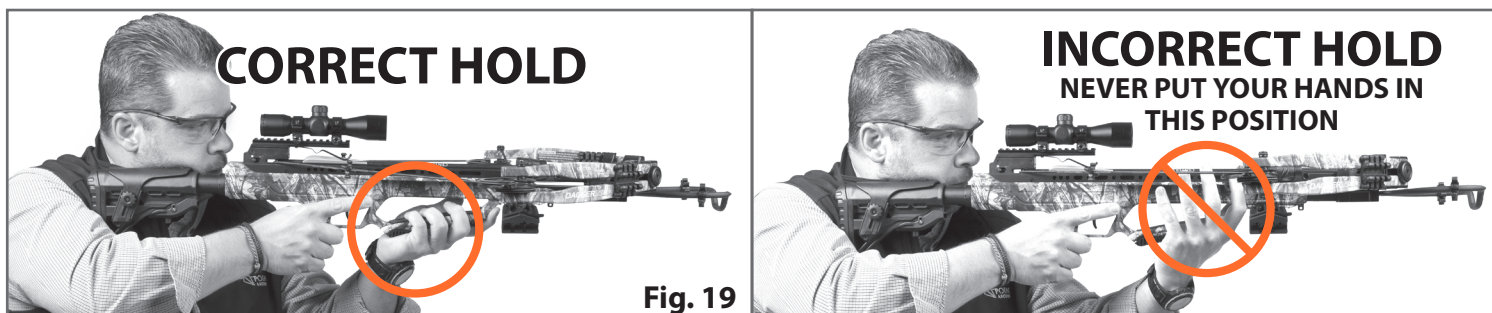

## B. Sighting in The Crossbow

- The crossbow is equipped with a scope. Follow the instructions included with the scope for sighting and adjusting.

## C. Firing

- With the crossbow pointed in a SAFE DIRECTION and hands in the proper position release the safety by pushing the safety all the way forward ("FIRE") (see section 5B).
- Pull the trigger.

## D. De-cocking the Crossbow

**⚠ WARNING:** DO NOT USE YOUR HAND OR THE ROPE COCKER TO UNCOCK THE CROSSBOW AS IT MAY CAUSE SERIOUS INJURY TO THE USER OR DAMAGE TO THE CROSSBOW.

- You should not cock or load the crossbow unless you are in a safe area and in a position to shoot safely.
- ALWAYS identify the target and beyond the target prior to shooting.
- If for some reason you must de-cock the crossbow, **DO NOT DRY FIRE IT.** Load an old arrow/bolt and fire into a safe target after following the instructions in this manual. Dry firing can cause serious injury or damage to the crossbow.

## 9. MAINTAINING THE CROSSBOW

- **NEVER DRY FIRE THE CROSSBOW.**
- **DO NOT MODIFY OR ALTER THE CROSSBOW.** Attempts to modify the crossbow in any way inconsistent with this manual may render the crossbow unsafe to use, cause serious injury or death, and will void the warranty.
- If you drop the crossbow, check to see that it works properly before you use it again. If anything seems changed, like a shorter or weaker trigger pull, this may mean broken parts.
- Always check the crossbow thoroughly for worn, damaged, loose or missing parts prior to shooting. Call customer service for assistance before using the crossbow again.
- Periodically place a light coat of silicon based lubricant on all metal parts to prevent rust and corrosion.
- We also recommend rail lube (included) to reduce fraying and wear. Apply a small amount of rail lube every 12-15 shots to the rail. DO NOT wax the center section of the crossbow's string because this can cause build up of wax to the trigger mechanism. Keep the flight rail lubed, and the string and cables waxed to reduce friction. Always check and replace frayed or worn strings and cables.
- Change strings when they become worn or frayed. Contact an established archery shop to change the strings. Changing strings requires experience and a bow press which can found at an established archery shop.
- Inspect all arrows/bolts for wear, damage, or nicks before using. If any wear, damage, or nicks are found dispose of the arrows/bolts properly.
- Always store your crossbow in a cool, dry place. Do not expose your crossbow to excessive heat such as leaving it in an automobile trunk on a hot day or storing it next to a furnace vent.

## Specifications

<b>Draw Weight</b>	185	<b>Trigger</b>	Patented Trigger Technology – Dry Fire Inhibitor
<b>FPS</b>	Up to 390	<b>Arrow Size</b>	20" Carbon with Half Moon Nock
<b>Stock</b>	Composite	<b>Mass Weight</b>	7.8 lbs
<b>Limb</b>	Compression Fiberglass	<b>Length</b>	35.8"
<b>Optics</b>	4x32	<b>Width</b>	18" Uncocked / 14" Cocked
<b>Riser</b>	Aluminum	<b>Arrow</b>	400 grain w/ Field Point

### LIMITED WARRANTY FOR CENTERPOINT CROSSBOW

Your CenterPoint® crossbow is warranted to be free of defects in materials and workmanship for 5 years from the date of purchase. This warranty is not transferable and as such is limited to the original owner. This warranty does not cover damages due to fair wear and tear, failure to provide routine maintenance, and does not include cables, strings or accessories. In the event of a defect under this warranty, we will, at our option, repair or replace the product; provided, however, our inspection indicates that an original defect exists. CenterPoint reserves the right to replace any product which is no longer available with a product of comparable value and function. If CenterPoint determines the repair is not covered under the warranty guidelines, there could be a charge to you for the repair. This is a limited warranty and does not cover damages caused by dry fire, misuse, improper handling or installation or maintenance provided by someone other than a CenterPoint Authorized Service Station.

THIS LIMITED WARRANTY DOES NOT INCLUDE CONSEQUENTIAL DAMAGES, INCIDENTAL DAMAGES, OR INCIDENTAL EXPENSES, INCLUDING DAMAGE TO PROPERTY OR ANY OTHER EXPENSE. CENTERPOINT DISCLAIMS ANY IMPLIED WARRANTIES, INCLUDING THE IMPLIED WARRANTIES OF MERCHANTABILITY AND FITNESS. SOME STATES DO NOT ALLOW THE EXCLUSION OR LIMITATION OF INCIDENTAL OR CONSEQUENTIAL DAMAGES, OR ALLOW LIMITATIONS ON IMPLIED WARRANTIES SO THE ABOVE LIMITATIONS OR EXCLUSIONS MAY NOT APPLY TO YOU. TO THE EXTENT ANY PROVISION OF THIS WARRANTY IS PROHIBITED BY FEDERAL, STATE OR MUNICIPAL LAW, WHICH CANNOT BE PREEMPTED, IT SHALL NOT BE APPLICABLE. THIS WARRANTY GIVES YOU SPECIFIC LEGAL RIGHTS, AND YOU MAY ALSO HAVE OTHER RIGHTS, WHICH VARY FROM STATE TO STATE AND COUNTRY TO COUNTRY.

### STOP – BEFORE YOU RETURN THIS PRODUCT TO THE STORE

Save on gas and avoid the trip back to the store. Contact our Customer Service/Technical Support representatives for information and trouble-shooting help at 1-866-726-1122 or visit our web site at [centerpointarchery.com](http://centerpointarchery.com).

### WARRANTY CLAIMS/ REPAIR SERVICE

If your product needs repair, DO NOT ATTEMPT TO DISASSEMBLE IT! Any disassembly or modification not performed by a Centerpoint Authorized Service Station will void the warranty.

**U.S. Customers** - Contact CenterPoint Customer Service -1-866-726-1122 or email us at [centerpointarchery.com](mailto:centerpointarchery.com). You will be instructed where and how to send your CenterPoint product in for repair/replacement under warranty or referred an authorized service center.

#### CenterPoint Archery

Attn: Warranty Dept.

7629 Route 5 & 20

Bloomfield, NY 14469

Include with your product a copy of your receipt and a brief description of the problem. Be sure to indicate your name, mailing address, email address and telephone number. Allow 2-4 weeks for product repair/replacement. We recommend you use a method of shipping that provides you with a tracking number and insurance options. CenterPoint is not liable for any merchandise damaged, lost or stolen during shipping to and from CenterPoint.

**Canadian Customers** - Contact the Gravel Agency, in Quebec at 866-662-4869.

**Outside U.S. Customers:** Please contact your point of purchase dealer/distributor. If you do not know your dealer/distributor, contact our International Dept. for assistance at 585-657-6161 or email us at [centerpointarchery.com](mailto:centerpointarchery.com).

CenterPoint and DAGGER are trademark of Crosman Corporation in the United States.

© 2019 Crosman Corporation

04-19 OM



A Velocity Outdoor Company  
7629 Routes 5 & 20  
Bloomfield, NY 14469  
United States of America  
1.866.726.1122  
[centerpointarchery.com](http://centerpointarchery.com)  
Made in Taiwan

AXCD190FCKA515